

INCH-POUND

MIL-PRF-3135H

18 September 2008

SUPERSEDING

MIL-PRF-3135G

21 March 1983

PERFORMANCE SPECIFICATION  
DECK COVERING UNDERLAY MATERIALS

This specification is approved for use by all Departments and Agencies of the Department of Defense.

1. SCOPE

1.1 Scope. This specification establishes the performance requirements for deck covering underlay materials to be applied over primed or unprimed, clean steel and aluminum interior deck surfaces on naval vessels in order to provide a smooth, level, and/or properly sloped surface over which a final deck covering system will be applied.

1.2 Classification. Deck covering underlay materials should be of the following types, classes, and grades as specified (see 6.2):

1.2.1 Types.

- a. Type I – Standard weight underlay materials for use under trowel applied deck coverings (such as MIL-PRF-24613).
- b. Type II – Standard weight underlay materials for use under pre-formed deck coverings (such as porcelain tiles, vinyl tiles, sheet vinyl, etc.).
- c. Type III – General use, ultra-lightweight underlay materials weighing no greater than 4.88 kilograms per square meter (1.0 pound per square foot) at a thickness of 6.4 millimeters (0.25 inch).
- d. Type IV – General use, lightweight polymeric underlayment materials weighing no greater than 7.81 kilograms per square meter (1.6 pounds per square foot) at a thickness of 6.4 millimeters (0.25 inch) that perform the functions normally provided by separate primer, underlayment, waterproof, and crack suppression membrane materials in one single, trowel, or spray applied product.

1.2.2 Classes.

- a. Class 1 – Latex base underlay materials
- b. Class 2 – Resin base underlay materials

1.2.3 Grades.

- a. Grade A – For use onboard submarines
- b. Grade B – For general shipboard use

Comments, suggestions, or questions on this document should be addressed to: Commander, Naval Sea Systems Command, ATTN: SEA 05M2, 1333 Isaac Hull Avenue, SE, Stop 5160, Washington Navy Yard DC 20376-5160 or emailed to [CommandStandards@navy.mil](mailto:CommandStandards@navy.mil), with the subject line "Document Comment". Since contact information can change, you may want to verify the currency of this address information using the ASSIST Online database at <http://assist.daps.dla.mil>.

2. APPLICABLE DOCUMENTS

2.1 General. The documents listed in this section are specified in sections 3, 4, or 5 of this specification. This section does not include documents cited in other sections of this specification or recommended for additional information or as examples. While every effort has been made to ensure the completeness of this list, document users are cautioned that they must meet all specified requirements of documents cited in sections 3, 4, or 5 of this specification, whether or not they are listed.

2.2 Government documents.

2.2.1 Specifications, standards, and handbooks. The following specifications, standards, and handbooks form a part of this document to the extent specified herein. Unless otherwise specified, the issues of these documents are those cited in the solicitation or contract.

DEPARTMENT OF DEFENSE SPECIFICATIONS

- MIL-DTL-24441 - Paint, Epoxy-Polyamide, General Specification for
- MIL-DTL-24441/20 - Paint, Epoxy-Polyamide, Green Primer, Formula 150, Type III
- MIL-DTL-24441/29 - Paint, Epoxy-Polyamide, Green Primer, Formula 150, Type IV

DEPARTMENT OF DEFENSE STANDARD

- MIL-STD-1623 - Fire Performance Requirements and Approved Specifications for Interior Finish Materials and Furnishings (Naval Shipboard Use)

(Copies of these documents are available online at <http://assist.daps.dla.mil/quicksearch/> or <http://assist.daps.dla.mil> or from the Standardization Document Order Desk, 700 Robbins Avenue, Building 4D, Philadelphia, PA 19111-5094.)

2.2.2 Other Government documents, drawings, and publications. The following other Government documents, drawings, and publications form a part of this document to the extent specified herein. Unless otherwise specified, the issues of these documents are those cited in the solicitation or contract.

BUREAU OF MEDICINE AND SURGERY (BUMED)

- BUMED INST 6270.8 - Procedures for Obtaining Health Hazard Assessments (HHAs)

(Copies of this document are available from Bureau of Medicine and Surgery, Department of the Navy, 2300 E Street, NW, Washington DC 20372-5300 or online at <https://bumed.med.navy.mil/>.)

CODE OF FEDERAL REGULATIONS (CFR)

- 29 CFR 1910.1000 - Air Contaminants
- 29 CFR 1915.1001, Appendix K, Method ID-191 - Polarized Light Microscopy of Asbestos
- 29 CFR 1990 - Identification, Classification, and Regulation of Potential Occupational Carcinogens
- 40 CFR 60, Ch.1, Appendix A-7, Method 24 - Determination of Volatile Matter Content, Water Content, Density, Volume Solids, and Weight Solids of Surface Coatings
- 40 CFR 63 - National Emission Standards for Hazardous Air Pollutants for Source Categories

MIL-PRF-3135H

- 40 CFR 63.782 - National Emission Standards for Shipbuilding and Ship Repair (Surface Coating) Definitions
- 40 CFR 82 - Protection of Stratospheric Ozone
- 40 CFR 261, Appendix II, Method 1311 - Toxicity Characteristic Leaching Procedure (TCLP)
- 40 CFR 302 - Designation, Reportable Quantities, and Notification
- 40 CFR 355 - Emergency Planning and Notification
- 40 CFR 372 - Toxic Chemical Release Reporting: Community Right-to-Know

(Copies of these documents are available from the Superintendent of Documents, U.S. Government Printing Office, Washington DC 20401 or online at [www.gpoaccess.gov/index.html](http://www.gpoaccess.gov/index.html).)

NAVAL SEA SYSTEMS COMMAND (NAVSEA)

- S9510-AB-ATM-010 - Nuclear Powered Submarine Atmosphere Control Manual, Chapter 7

(Copies of this chapter are available online at <https://smcl.dt.navy.mil> or from Commander, Naval Sea Systems Command, ATTN: SEA 05Z9, 1333 Isaac Hull Ave. SE Stop 5122, Washington Navy Yard DC 20376-5122.)

UNITED STATES ENVIRONMENTAL PROTECTION AGENCY (EPA)

- EPA SW-846 - Test Methods for Evaluating Solid Waste, Physical/Chemical Methods
- EPA 600/4-79-020 - Methods for Chemical Analysis of Water and Wastes

(Copies of these documents are available from the Environmental Protection Agency, Ariel Rios Building, 1200 Pennsylvania Avenue, N.W., Washington DC 20460 or online at [www.epa.gov](http://www.epa.gov).)

INTERNATIONAL AGENCY FOR RESEARCH ON CANCER (IARC)

Monographs

(Copies of this document are available from International Agency for Research on Cancer, WHO Publication Center, 49 Sheridan Ave., Albany, NY 12210 or online at [www.iarc.fr](http://www.iarc.fr).)

NATIONAL TOXICOLOGY PROGRAM (NTP)

Annual Report on Carcinogens

(Copies of this document are available from U.S. Department of Health and Human Services, Public Information Office, P.O. Box 12233, MD B2-04, Research Triangle Park, NC 27709 or online at <http://ntp-server.niehs.nih.gov>.)

2.3 Non-Government publications. The following documents form a part of this document to the extent specified herein. Unless otherwise specified, the issues of these documents are those cited in the solicitation or contract.

ASTM INTERNATIONAL

- ASTM B117 - Standard Practice for Operating Salt Spray (Fog) Apparatus (DoD adopted)
- ASTM D609 - Standard Practice for Preparation of Cold-Rolled Steel Panels for Testing Paint, Varnish, Conversion Coatings, and Related Coating Products (DoD adopted)

ASTM D2240	-	Standard Test Method for Rubber Property – Durometer Hardness (DoD adopted)
ASTM D3278	-	Standard Test Methods for Flash Point of Liquids by Small Scale Closed-Cup Apparatus (DoD adopted)
ASTM F718	-	Shipbuilders and Marine Paints and Coatings Product/Procedure Data Sheet (DoD adopted)

(Copies of these documents are available from ASTM International, 100 Barr Harbor Dr., P.O. Box C700, West Conshohocken, PA 19428-2959 or online at [www.astm.org](http://www.astm.org).)

The Society for Protective Coatings (SSPC)

SSPC-SP 3	-	Power Tool Cleaning (DoD adopted)
SSPC-SP 11	-	Power Tool Cleaning to Bare Metal (DoD adopted)

(Copies of these documents are available from the Society for Protective Coatings (SSPC), 40 24th Street, 6th Floor, Pittsburgh, PA 15222 or online at [www.sspc.org](http://www.sspc.org).)

2.4 Order of precedence. In the event of a conflict between the text of this document and the references cited herein, the text of this document takes precedence. Nothing in this document, however, supersedes applicable laws and regulations unless a specific exemption has been obtained.

### 3. REQUIREMENTS

3.1 Qualification. The underlay materials furnished under this specification shall be products that are authorized by the qualifying activity for listing on the applicable qualified products list before contract award (see 4.2 and 6.4).

3.2 Composition. Class 1 underlayment materials shall consist of a pre-mixed aggregate and latex powder (that only requires the addition of water at time of installation). Class 2 products shall consist of three components: a resin, hardener, and separate aggregate. The deck covering underlay materials shall be suitable for application with a trowel after mixing by hand or with commonly available mixing tools. No specialized mixing equipment shall be required. Mixing instructions, including any induction times or other requirements, shall be as supplied by the manufacturer. Type I or Type II materials may include a separate primer as part of the system, or may require the deck to be primed prior to underlayment application. Types III and IV materials shall be able to be applied directly to a clean, bare metal substrate without requiring a separate primer (other than a bond coat of the base material without aggregate) while still meeting all the performance requirements of this specification.

3.3 Resin based systems (Class 2 materials). The manufacturer is given their choice of ingredients used in the formation of the resin described in this document. For resin based systems, the allowed proportions for the ratio of resin component to hardener shall be limited to 4:1, 3:1, 2:1, or 1:1 by volume, where manufacturer's instructions allow products to be mixed in the field by underlayment installers. When mixed and applied in accordance with the manufacturer's instructions, the final underlayment system shall be in accordance with all requirements of this specification.

3.4 Application. The deck covering underlay materials shall adhere to the deck or structure on which applied without the use of clips or other devices welded to the deck, or other reinforcement not a part of the compound as mixed for application. Types I and II underlay materials shall be applied to clean steel surfaces which have been primed with Formula 150 in accordance with MIL-DTL-24441 and MIL-DTL-24441/20, MIL-DTL-24441/29 or an alternative primer (e.g. an approved primer under MIL-PRF-23236 or MIL-PRF-24647) if provided by the manufacturer as part of the underlay system. Types III and IV underlay materials shall be applied to a clean, unprimed metal surface, prepared in accordance with SSPC-SP 3 at a minimum.

### 3.5 Performance requirements.

3.5.1 **Toxicity.** No component of the underlay system shall have any adverse effect on the health of personnel when used for its intended purpose. The materials used in the underlayment shall have no known carcinogenic or potentially carcinogenic materials identified by OSHA (29 CFR 1990) as regulated carcinogens, the IARC latest Monographs, and the latest Annual Report on Carcinogens of the NTP; and shall have no extremely hazardous substances (EHS) or toxic chemicals identified in 29 CFR 1910.1000, 40 CFR 302, 40 CFR 355, and 40 CFR 372, respectively. The use of any Ozone-Depleting Substance (ODS) in any component of the underlay system under this specification, directly or referenced in any test method, is prohibited. Class I or Class II ozone-depleting chemicals are defined by 40 CFR 82. The manufacturer is responsible for maintaining carcinogenic free, extremely hazardous substance free, and toxic chemical free materials. The manufacturer shall not, unless specific material maximum levels are cited herein, allow the addition of any of these prohibited materials to the formulation. When any of these prohibited materials are/may be present, as a result of being present as a trace or impurity in other ingredient(s), the concentration of the prohibited material shall not exceed 0.01 percent by weight in any component of the underlayment system.

3.5.1.1 **Asbestos content.** The percent by weight of asbestos in the dry underlayment shall not be in excess of 0.0005% wt as analyzed in accordance with OSHA Validated Analytical Method ID-191, "Polarization Light Microscopy of Asbestos".

3.5.1.2 **Metal content.** The metal content (soluble and total) of any component of the underlay system shall be less than the values listed in Table I when tested in accordance with 4.5.1. If the test for total metal results in a value less than the soluble metal limit, the soluble metal test need not be conducted. The soluble metal and total metal values shall be reported in Table I results.

TABLE I. Metals content of underlay components.

<b>Metal and its compound in each underlayment dry film</b>	<b>Soluble metal, maximum mg/L (lb/gal)</b>	<b>Total content, maximum % weight</b>
Antimony	15.0 ( $1.3 \times 10^{-4}$ )	0.015
Arsenic	5.0 ( $4.2 \times 10^{-5}$ )	0.005
Barium (excluding barite)	100.0 ( $8.3 \times 10^{-3}$ )	0.10
Beryllium	0.75 ( $6.3 \times 10^{-6}$ )	0.0002
Cadmium	1.0 ( $8.3 \times 10^{-6}$ )	0.0005
Chromium VI compounds	1.0 ( $8.3 \times 10^{-6}$ )	0.001
Chromium and chromium III compounds	560.0 ( $4.7 \times 10^{-3}$ )	0.56
Cobalt*	50.0 ( $4.2 \times 10^{-4}$ )	0.005
Copper	25.0 ( $2.1 \times 10^{-4}$ )	0.01
Fluoride salts	180.0 ( $1.5 \times 10^{-3}$ )	0.18
Lead	5.0 ( $4.2 \times 10^{-5}$ )	0.005
Mercury	0.2 ( $1.7 \times 10^{-6}$ )	0.0002
Molybdenum	350.0 ( $2.9 \times 10^{-3}$ )	0.035
Nickel	20.0 ( $1.7 \times 10^{-4}$ )	0.02
Selenium	1.0 ( $8.3 \times 10^{-6}$ )	0.002
Silver	5.0 ( $4.2 \times 10^{-5}$ )	0.001
Tantalum	100.0 ( $8.3 \times 10^{-4}$ )	0.100
Thallium	7.0 ( $5.8 \times 10^{-5}$ )	0.007
Tungsten	100.0 ( $8.3 \times 10^{-4}$ )	0.100
Vanadium	24.0 ( $2.0 \times 10^{-4}$ )	0.01
Zinc	250.0 ( $2.1 \times 10^{-3}$ )	0.25

\* Total cobalt content may exceed 0.005 % wt (up to 0.2 % wt) only if a cobalt drier is used to effect proper drying. Regardless of whether a cobalt drier is used, soluble cobalt content may not exceed Table I requirements.

3.5.1.3 **Hazardous air pollutants (HAPs).** The content of the HAPs solvents in any component of the underlayment system shall not exceed the weight percent (% wt) values listed in Table II. Within these limitations and the requirement that the finished underlay meets all requirements of this specification, solvent selection is the responsibility of the manufacturer. HAP materials are defined by 40 CFR 63.

TABLE II. Hazardous air pollutant solvent content limits.

<b>Hazardous solvent in mixed underlayment or its components</b>	<b>Maximum % wt</b>
Benzene	0.05
Chlorinated solvent(s), total	0.05
Solvents containing fluorine as defined by 40 CFR 82	0.01
Ethyl benzene	0.05
Methyl, Ethyl, and Butyl mono-ethers of ethylene glycol or the acetates thereof, total (also known as methyl, ethyl, and butyl cello solves and methyl, ethyl, and butyl cello solve acetates)	0.05
Methyl ethyl ketone (MEK)	0.05
Methyl isobutyl ketone (MIBK)	0.05
Toluene	0.05
Xylene (all forms), total	0.1

3.5.1.4 **Volatile organic content (VOC).** The VOC of Types I and II underlay systems shall not exceed 250 grams per liter (2.08 pounds per gallon). The VOC of Types III and IV materials shall be 0 grams per liter (0 pounds per gallon).

3.5.1.5 **Solvents and thinners.** Thinning of VOC compliant underlayment is not allowed. The underlay system components shall be able to be adequately mixed by hand and applied by trowel to the deck at any temperature above 10°C (50 °F) without the addition of thinning agents.

3.5.2 **Flash point.** The flash point of the underlayment or any component shall not be less than 38 °C (100 °F).

3.5.3 **Weight.** After the underlayment has fully cured, the material shall not exceed the following maximum weight limits:

a. Type I:

- (1) Class 1: 8.54 kilograms per square meter (1.75 pounds per square foot) at a thickness of 6.4 millimeters (0.25 inch).
- (2) Class 2: 12.2 kilograms per square meter (2.50 pounds per square foot) at a thickness of 6.4 millimeters (0.25 inch).

b. Type II (All Classes): 12.2 kilograms per square meter (2.50 pounds per square foot) at a thickness of 6.4 millimeters (0.25 inch).

c. Type III (All Classes): 4.88 kilograms per square meter (1.00 pound per square foot) at a thickness of 6.4 millimeters (0.25 inch).

d. Type IV (All Classes): 7.81 kilograms per square meter (1.60 pounds per square foot) at a thickness of 6.4 millimeters (0.25 inch).

3.5.4 **Resistance to impact.** The deck covering underlay materials shall not show visible signs of chipping, cracking, or detachment from the steel plate. There shall be not more than 1.59 millimeters (0.0625 inch) of permanent indentation for Types I, II, and III, and not more than 0.7936 millimeter (0.03125 inch) of permanent indentation for Type IV.

3.5.5 Indentation.

3.5.5.1 Initial Indentation. The percent initial indentation of the deck covering underlay material shall be as follows:

	Type I				Type II				Type III	Type IV
	Class 1		Class 2		Class 1		Class 2		All Classes	All Classes
	Min (%)	Max (%)	Min (%)	Max (%)	Min (%)	Max (%)	Min (%)	Max (%)	Max (%)	Max (%)
Material cured 48 hours	---	40	---	10	---	40	---	10	10	25
Material cured 96 hours	1	40	---	10	1	5	---	5	5	7.5

3.5.5.2 Residual indentation. The residual indentation of all materials shall not be greater than the following maximum percentages:

	Type I	Type II	Type III	Type IV
	Max (Percent)	Max (Percent)	Max (Percent)	Max (Percent)
Material cured 96 hours	38	5	1	1

3.5.6 Resistance to elevated temperatures. The deck covering underlay materials shall not soften detectably by touch, nor have a measured slip greater than 0.7936 millimeter (0.03125 inch).

3.5.7 Resistance to moisture and temperature changes. The deck covering underlay materials shall show no signs of cracking, separation from the steel plate, or corrosion of the steel beneath the underlayment.

3.5.8 Moisture absorption.

3.5.8.1 Type I, Class 1. Type I, Class 1 materials shall not absorb greater than 5 percent of moisture based on its weight at normal atmospheric conditions.

3.5.8.2 Type I, Class 2. Type I, Class 2 materials shall not absorb greater than 2 percent of moisture based on its weight at normal atmospheric conditions.

3.5.8.3 Types II and III. Type II and III materials shall not absorb greater than 1 percent of moisture, based on its weight at normal atmospheric conditions.

3.5.8.4 Type IV. Type IV materials shall not absorb greater than 0.1 percent of moisture, based on its weight at normal atmospheric conditions.

3.5.9 Resistance to chemicals (Types II and III). When tested as specified in 4.5.9, the deck covering underlay material shall not exceed the following changes in weight and volume:

Chemical	Weight change (Percent maximum)	Volume change (Percent maximum)
Oil	6.5	2
JP-5	6.5	2
AFFF (50% solution)	4	2
10% Sulfuric Acid	4	2

3.5.10 Resistance to corrosion. The deck covering underlay material shall not soften or become detached, and the surface of the steel beneath the deck covering underlay material shall show no signs of corrosion, capillary action (wicking), or other water penetration under the underlay.

3.5.11 Fire performance. Deck covering underlay shall meet the fire resistance requirements specified in MIL-STD-1623 for underlay.

3.5.12 Adhesive strength.

3.5.12.1 Initial adhesive strength. The initial adhesive strength of the deck covering underlay materials shall be not less than 1034 kilopascals (150 pounds per square inch).

3.5.12.2 Adhesive strength after aging. The adhesive strength of the deck covering underlay materials after aging shall be not less than 85 percent of the initial adhesive strength.

3.5.12.3 Adhesive strength after exposure. The adhesive strength of the deck covering underlay materials after exposure to moisture and temperature shall be not less than 95 percent of the initial adhesive strength.

3.5.13 Flexibility (Type IV only). Type IV materials shall exhibit no chipping, cracking, or permanent deformation when tested as specified in 4.5.13.

3.5.14 Serviceability. The deck covering underlay material shall satisfactorily perform its function when examined during and after the minimum shipboard service period specified in 4.5.14.

3.5.15 Off-gassing (Grade A only). The underlayment system (including any required primer and/or bond coat) shall be tested for off-gassing in accordance with Chapter 7 of NAVSEA S9510-AB-ATM-010, and shall be certified for and assigned a usage category of either "Limited" or "Permitted" (see 4.5.15 and 6.6).

4. VERIFICATION

4.1 Classification of tests. The inspection requirements specified herein are classified as follows:

- a. Qualification tests (see 4.2).
- b. Conformance tests (see 4.3).

4.2 Qualification tests. Qualification tests shall consist of all of the tests listed in Table III and shall be conducted at a laboratory satisfactory to the Naval Sea Systems Command (NAVSEA).

4.2.1 Qualification sample. The qualification sample shall be drawn from a production batch and shall consist of enough component materials (e.g., aggregate, hardener, and resin if a resin based system) to create 7.6 liters (2 gallons) of the final mixed underlayment.

4.2.2 Formulation changes. Any change in basic ingredients or manufacturing processes (other than minor changes in pigment concentrations strictly to adjust final underlayment system color) that would affect compliance with this specification must be reported to both the contracting activity and NAVSEA. The Government reserves the right to require that all tests specified in this specification be re-performed on a production batch of the underlayment produced under the new formulation or process before any shipment is accepted. Any formulation change not disclosed to NAVSEA will result in immediate disqualification of the product.

4.3 Conformance tests. Conformance tests shall consist of specific tests identified in Table III.

4.3.1 Lot. All unmixed material of the same type, but not more than a daily production run, offered for delivery at one time, shall be considered a lot for purposes of conformance testing. The addition of any substance to a batch shall constitute a new lot and full conformance testing is required.

4.3.2 Sampling for conformance testing. The contractor shall select a production sample sufficiently large enough to permit the performance of all conformance tests. At a minimum, two containers shall be selected from each lot of rubber latex or two containers of both resin and hardener, and from each lot of underlay powder. From each of the containers, enough material to provide for the application over a 0.8-square meter (9-square foot) area at a thickness of 6.4 millimeters (0.25 inch) (approximate) shall be taken. If testing cannot be performed at the manufacturer's facilities, two representative packaged samples shall be forwarded to an unaffiliated third party laboratory for verification tests. If the underlay material is to be applied to sample panels at the vendor's facility and forwarded to an external laboratory for testing, preparation of the panels and application of the underlayment system must be observed by a representative from the Defense Contracts Management Agency (DCMA).

4.3.3 Fire performance testing. A running total of material produced for batches shall be kept. Manufacturers' records shall be used to determine quantities of material delivered. The fire performance tests of MIL-STD-1623 (see 3.5.11 and 4.5.11) shall be conducted as part of the lot acceptance tests once for every 45,359 kilograms (100,000 pounds) of unmixed material produced for delivery under one or more contracts or orders. If any sample fails any fire performance test, the tests of 4.5.11 shall be run on every subsequent batch until four successive batches have passed all required fire performance tests.

4.3.4 Small lots. Conformance tests shall not be required on any delivery of less than 4535 kilograms (10,000 pounds) of unmixed material. However, deliveries of such small quantities that have not been tested shall be so identified in the manufacturer's records. Once the accumulated total of such untested deliveries reaches 4535 kilograms (10,000 pounds), sample material shall be selected and subjected to the required conformance tests identified in Table III.

TABLE III. Tests.

Item	Qualification testing required	Conformance testing required	Requirement paragraph	Test method paragraph
Toxicity	Yes	No	3.5.1	4.5.1
Asbestos content	Yes	No	3.5.1.1	4.5.1.1
Total and soluble metal content	Yes	No	3.5.1.2	4.5.1.2
Hazardous air pollutant (HAP) content	Yes	No	3.5.1.3	4.5.1.3
Volatile organic content (VOC)	Yes	Yes	3.5.1.4	4.5.1.4
Flash point	Yes	Yes	3.5.2	4.5.2
Weight	Yes	Yes	3.5.3	4.5.3
Resistance to impact	Yes	Yes	3.5.4	4.5.4
Initial indentation	Yes	Yes	3.5.5.1	4.5.5.1
Residual indentation	Yes	Yes	3.5.5.2	4.5.5.2
Resistance to elevated temperatures	Yes	No	3.5.6	4.5.6
Resistance to moisture and temperature changes	Yes	No	3.5.7	4.5.7
Moisture absorption	Yes	Yes	3.5.8	4.5.8
Resistance to chemicals	Yes	No	3.5.9	4.5.9
Resistance to corrosion	Yes	No	3.5.10	4.5.10
Fire performance	Yes	Yes (See 4.3.3)	3.5.11	4.5.11
Initial adhesive strength	Yes	Yes	3.5.12.1	4.5.12.1
Adhesive strength after aging	Yes	No	3.5.12.2	4.5.12.2
Adhesive strength after exposure	Yes	No	3.5.12.3	4.5.12.3
Flexibility (Type IV only)	Yes	Yes	3.5.13	4.5.13
Serviceability	Yes	No	3.5.14	4.5.14
Off-gassing (Grade A only)	Yes	No	3.5.15	4.5.15

4.3.5 Noncompliance. If a sample fails to pass its conformance inspections, the lot shall be rejected and the manufacturer shall notify the cognizant inspection activity of such failure and take corrective action on the materials or processes, or both, as warranted. Acceptance and shipment of the product shall be discontinued until corrective action, suitable to the inspection activity, has been taken. After the corrective action has been taken, conformance inspections shall be repeated on the new lot. In the event of failure after re-inspection, information concerning the failure shall be furnished to the cognizant inspection activity.

4.4 Inspection conditions. Unless otherwise specified (see 6.2), all tests shall be performed under referee conditions for temperature and relative humidity. The term referee conditions shall mean a temperature of  $23\pm 1$  °C ( $73\pm 2$  °F) and a relative humidity of  $50\pm 4$  percent. All paint test specimens shall be cured to service in accordance with manufacturer's ASTM F718 sheet before testing unless otherwise specified (see 6.2).

4.4.1 Test panels and surface preparation. Unless otherwise specified (see 6.2), test panels shall be 150 by 150 by 3 millimeters (6 by 6 by 0.125 inch) cold rolled steel. Test panels shall be preconditioned by exposing the bare metal panels to a salt fog spray for 100 hours in accordance with ASTM B117. Test panels shall then be wiped and degreased in accordance with Method B, C, or D of ASTM D609. The degreased test panels shall be mechanically cleaned in accordance with SSPC-SP 3 on both sides. For direct-to-metal underlayment systems (including all Type III and Type IV products), the panels shall remain unprimed prior to application of the underlayment system. For Type I or II underlayment systems requiring an anti-corrosive primer, the panels shall be primed with the primer included by the manufacturer as part of the underlayment system, or with a primer conforming to MIL-DTL-24441/20 or MIL-DTL-24441/29 if no specific primer is identified by the manufacturer.

#### 4.5 Tests.

4.5.1 Toxicity. To determine conformance with the requirements of 3.5.1, the material shall be evaluated by the Navy and Marine Corps Public Health Center using the administrative Health Hazard Assessment (HHA) (see 6.7).

4.5.1.1 Asbestos content. Asbestos content shall be determined on a dry film of the underlayment in accordance with 29 CFR 1915.1001, Appendix K, Method ID-191, and the results shall be recorded as a percent by weight of the dry underlayment film.

4.5.1.2 Soluble and total metal content. Soluble and total metal content, except tantalum and tungsten, shall be determined on a dry paint film of the underlayment in accordance with 40 CFR 261, Appendix II, Method 1311, and the appropriate test listed in Tables IV and V. Tantalum and tungsten soluble metal content and total metal content shall be analyzed as specified in 4.5.1.2.1.

TABLE IV. Test methods for evaluating solid waste physical/chemical methods, EPA SW-846.

<b>Metal/material</b>	<b>Digestion test method</b>
All metals, except chromium (VI)	3050
Chromium (VI)	3060
Antimony	7040 or 7041
Arsenic	7060 or 7061
Barium	7080 or 7081
Cadmium	7131
Total chromium	7190
Chromium (VI)	7195, 7196, or 7197
Lead	7421
Mercury	7470 or 7471
Nickel	7520 or 7521
Selenium	7740 or 7741
Silver	7760 or 7761

TABLE V. Methods for chemical analysis of water and waste, EPA 600/4-79-020.

<b>Metal/material</b>	<b>Test method</b>
Beryllium	210.1 or 210.2
Cobalt	219.1 or 219.2
Copper	220.1 or 220.2
Fluoride	340.1, 340.2 or 340.3
Molybdenum	246.1 or 246.2
Thallium	279.1 or 279.2
Vanadium	286.1 or 286.2
Zinc	289.1 or 289.2

4.5.1.2.1 Tantalum and tungsten content. The tantalum and tungsten content of the underlayment shall be determined using any appropriate spectroscopy test method. The tests shall be conducted in accordance with the equipment manufacturer's directions for the use of the instrument. The underlayment manufacturer is responsible for establishing data justifying the test method choice and analytical accuracy.

4.5.1.3 Hazardous air pollutant (HAP) content. Formulation data shall be used by manufacturers in lieu of testing to demonstrate compliance with HAP requirements of this specification. The manufacturer's formulation data must have a consistent and quantitatively known relationship to the testing required. Calculation of individual HAP contents can be based on either manufacturer evaluation of batches or supplier data for raw materials used in the product. The underlayment manufacturer must provide, for each individual HAP, a formulation value that will not be exceeded if a sample from any quality control approved production batch of the underlayment is evaluated in accordance with this paragraph.

4.5.1.4 Volatile organic content (VOC). VOC for each batch (as described in 40 CFR 63.782) shall be determined in accordance with 40 CFR 60 Ch.1, Appendix A, Method 24, allowing the sample to reside at  $22\pm 1$  °C ( $72\pm 2$  °F) for 24 hours prior to conducting the analysis. No oven heating is allowed.

4.5.2 Flash point. The flash point of each component shall be determined in accordance with ASTM D3278.

4.5.3 Weight. Three panels shall be prepared in accordance with 4.4.1. These panels shall then be weighed and the uncovered weight of each panel recorded to the nearest 0.05 kilogram (0.01 pound). The deck covering underlay material shall then be applied at a thickness of 6.4 millimeters (0.25 inch) (not including the plate and primer thicknesses). When the material has fully cured at referee conditions in accordance with manufacturer's instructions, the three test specimens shall then be weighed to the nearest 0.05 kilogram (0.01 pound). The uncovered weight of each steel plate recorded earlier shall then be subtracted from the weight of that same plate with the cured underlayment. These weights shall then be multiplied by a factor of four to give pounds per square foot at a thickness of 6.4 millimeters (0.25 inch) for each panel. The results from the three test panels shall then be averaged, and the final average pounds per square foot at a thickness of 6.4 millimeters (0.25 inch) of the material recorded.

4.5.4 Resistance to impact. Two panels shall be prepared in accordance with 4.4.1. The underlayment system shall then be applied to both panels at a thickness of 6.4 millimeters (0.25 inch) (not including the plate and primer thicknesses), and allowed to fully cure at referee conditions in accordance with manufacturer's instructions. Measurements of the thickness of the material shall be made at the geometric center of the sample and at nine other random points, to ensure the underlayment thickness at all points is  $6.4\pm 0.7937$  millimeter ( $0.25\pm 0.03125$  inch). The first specimen shall be firmly mounted on a solid horizontal base. A 0.9-kilogram (2-pound) steel ball shall be dropped vertically from a height of 2.4 meters (8 feet) onto the underlayment, such that the impact will be at the center of the specimen. The specimen shall be subjected to two impacts of the ball. The underlay shall then be visually examined for chipping, cracking, or delamination from the steel plate. The thickness of the underlayment at the point of impact of both balls shall then be measured. The residual indentation shall then be measured by calculating the difference between the thickness of the underlayment at the center of the sample before impact and the thickness of the underlayment at the center of the sample after impact. This procedure shall then be repeated on the second panel, and the two residual indentation results averaged and recorded.

4.5.5 Indentation. Four panels shall be prepared in accordance with 4.4.1. The underlayment system shall be applied to each panel at a thickness of 6.4 millimeters (0.25 inch). Two panels shall be allowed to cure for 96 hours at referee conditions. Two panels shall only be allowed to cure for 24 hours at referee conditions. The thickness of the underlayment shall be measured in three locations not less than 38 millimeters (1.5 inches) from any edge of the specimen, and not less than 64 millimeters (2.5 inches) from the center of an adjoining measurement. The thickness of the underlayment at each of these three locations shall be measured with a micrometer dial gage with a 0.1-kilogram (4-ounce) weight and a flat foot with a 6.4-millimeter (0.25-inch) diameter, to an accuracy of  $\pm 0.7937$  millimeter ( $\pm 0.03125$  inch). A permanent marker shall be used to mark these three locations. Each panel shall be mounted on a plate designed to support both the panel and a load of 907.2 kilograms (2,000 pounds) without allowing the specimen to slide. The specimen mounting plates selected for the indentation tests shall be checked for flatness before being used. Indentations shall be made on the deck covering underlay material at each of these three locations by placing a load of 907.2 kilograms (2,000 pounds) over a flat faced, circular indenter for 30 minutes at each spot. The indenter's flat face shall have an area of 1 square inch and its perimeter shall be rounded to a radius of 0.39688 millimeter (0.015625 inch). Care shall be taken to ensure that specimen is maintained parallel and level to the ground throughout the 30-minute indentation period.

4.5.5.1 Initial indentation. Immediately after the weight is lifted from each spot on each panel, the thickness of the underlayment shall be measured at that spot. The thickness of the underlayment immediately after the weight is removed shall then be subtracted from the thickness of the underlayment measured initially at that location. The difference shall then be divided by the original measured thickness (before the weight was applied) and the result multiplied by 100 percent. The initial indentation percentages for each of the three spots on a given panel shall then be averaged and the average initial indentation percentage recorded for that panel. Follow the same procedure for the remaining three panels.

4.5.5.2 Residual indentation. Two hours after the weight is lifted from each spot on each panel, the thickness of the underlayment shall be measured again at that spot. The thickness of the underlayment two hours after removal of the weight shall then be subtracted from the thickness of the underlayment measured initially (before the weight was applied) at that location. This difference shall then be divided by the original measured thickness (before the weight was applied) and the result multiplied by 100 percent. The residual indentation percentages for each of the three spots on a given panel shall then be averaged and the average residual indentation percentage recorded for that panel. Follow the same procedure for the remaining three panels.

4.5.6 Resistance to elevated temperatures. Two plates shall be prepared in accordance with 4.4.1, with the exception that the plates shall be ~~150 millimeters by 50 millimeters by 3.18 millimeters (6 inches by 2 inches by 0.125 inch)~~. The underlayment shall be applied to each plate at a thickness of 6.4 millimeters (0.25 inch) thickness and allowed to cure to service per manufacturer's instructions. The underlayment shall then be scribed with a line parallel to and approximately 25 millimeters (1 inch) from one of the 51-millimeter (2-inch) edges. The edge closest to the scribe shall be identified as the "reference edge." The distance between this line and the reference edge of each steel plate shall be measured to the nearest 0.25 millimeter (0.01 inch). The specimens shall then be suspended vertically from the end opposite the reference edge in an oven maintained at a constant temperature of  $71.1 \pm 1.1$  °C ( $160 \pm 2$  °F) for 5 hours. Immediately after the 5-hour period, remove the panels from the oven; examine the underlayment for softening by touch (wear gloves) on the end opposite the "reference edge." The specimens shall then be allowed to cool to room temperature. When the specimens have cooled to room temperature, the distance between the "reference edge" and the scribe on each plate shall be measured again. The difference in the distance between the scribe and the "reference edge" before and after heating shall be calculated for each plate, and the results averaged and recorded as the underlayment slip.

4.5.7 Resistance to moisture and temperature changes. Two panels shall be prepared in accordance with 4.4.1, with the exception that the plates shall be 150 by 50 by 3.18 millimeters (6 by 2 by 0.125 inch). The underlayment shall be applied to each plate at a thickness of 6.4 millimeters (0.25 inch) and allowed to cure to service per manufacturer's instructions. Both panels shall then be immersed in a solution of 4 percent sodium chloride in water, under a pressure of 55 kilopascals (8 pounds per square inch), for 48 hours. Immediately following the immersion period, the specimens shall be subjected to two complete cycles of alternate exposure to a temperature of  $-18\pm 3$  °C ( $0\pm 5$  °F) for 24 hours, followed by a temperature of  $49\pm 3$  °C ( $120\pm 5$ ) °F for 24 hours. The deck covering underlay material shall then be visually examined for evidence of cracking or other failure. A portion of the underlayment shall then be carefully removed from the plate to observe any signs of rusting or corrosion beneath the underlayment.

4.5.8 Moisture absorption. Three panels of cold rolled steel with dimensions of 50 by 50 by 3.18 millimeters (2 by 2 by 0.125 inch) shall be prepared by submerging the panels in oil and then removing them without cleaning or wiping the oil from the surface. The underlayment shall be applied to the panels at a thickness of 6.4 millimeters (0.25 inch) and allowed to cure to service at referee conditions in accordance with manufacturer's instructions; however, the underlayment shall not adhere to the oiled plates. Each fully cured specimen of underlayment (after being removed from the steel backing plate) shall then be completely submerged in tap water at room temperature, then immediately removed. All surfaces shall be lightly wiped with a paper towel to remove excess water from the surface of the underlayment, and then immediately weighed to the nearest 0.1 gram (0.004 ounce). After this initial weight has been recorded, the specimens shall be fully immersed again in room temperature tap water for a period of 24 hours. After 24 hours, the specimens shall be removed, lightly wiped with paper towels to remove excess water from the surface, and again weighed to the nearest 0.1 gram (0.004 ounce). The weight of the sample after initial dipping in tap water shall be subtracted from the weight of the sample after the 24-hour immersion period, and the difference recorded. The percent gain in moisture for each sample shall then be calculated by dividing this weight difference by the weight of the sample after the initial dipping in tap water, and multiplying by 100 percent. The percent moisture absorption shall then be averaged for all three samples, and the result recorded.

4.5.9 Resistance to chemicals. Eight panels shall be prepared for the moisture absorption test in 4.5.8. Two underlayment specimens (after being removed from the steel backing plate) shall be completely immersed into SAE 10W-40 oil, then removed and rinsed in room temperature tap water. Each specimen shall then be blotted dry with filter paper, free of lint and foreign material, and weighed in air to the nearest 0.01 gram (0.004 ounce), the weight recorded as  $W_1$ . Each sample shall then be weighed in tap water free of air bubbles (water may be boiled and returned to room temperature to remove air) as follows:

Using an analytical balance equipped with a hanging balance pan (if the balance is not of this construction density, measurement adapter kits are available) and a stationary support for the immersion vessel (beaker) above the balance pan (pan straddle), volume changes by measuring water displacement can be determined. Mount the beaker on the support that straddles the weighing pan. Attach to the balance hook a fine stainless wire sufficiently long to hold the specimen completely immersed in the water in the beaker. The sample holder or specimen must not touch the beaker. Remove any air bubbles adhering to the specimen or holder by rubbing them with a separate wire. Weigh the suspended specimen totally immersed in water to the nearest 0.01 gram (0.004 ounce), the weight recorded as  $W_2$ . Note that if the test specimen floats in the water, an AISI No. 316 stainless steel sinker can be used as ballast to immerse the test specimen. The following procedure can be used to adjust the calculation. Weigh the test specimen with ballast in water, then weigh the ballast alone in water and determine the difference between both weights and proceed with the calculations using this as  $W_2$ .

The samples shall be blotted dry as before and immediately immersed for 24 hours in the same oil. At the end of the required immersion period, the specimens shall be blotted as before and again weighed in air and while totally immersed in tap water, the weights recorded as  $W_3$  and  $W_4$ , respectively. The weight percent change and volume change shall then be calculated as follows:

$$\text{Weight change, \%} = \frac{W_3 - W_1}{W_1} \times 100\%$$

$$\text{Volume change, \%} = \frac{(W_3 - W_4) - (W_1 - W_2)}{(W_1 - W_2)} \times 100\%$$

The results from the two specimens shall be averaged, and the average percent weight change and volume change recorded. This procedure shall be repeated on the next set of two specimens, with the exception that the panels shall be immersed in JP-5 jet fuel instead of SAE 10W-40 oil. The procedure shall then be repeated on the next set of two specimens, immersing the specimens in a 50 percent solution of aqueous film forming foam (AFFF) instead of JP-5. The procedure shall then be repeated on the final set of two specimens by immersing them in a 10 percent sulfuric acid solution instead of a 50 percent AFFF solution. The average percent change in weight and percent change in volume after immersion in each fluid shall then be recorded.

4.5.10 Resistance to corrosion. Two panels shall be prepared in accordance with 4.4.1, with the exception that the panels shall be cold rolled steel, 150 by 50 by 3.18 millimeters (6 by 2 by 0.125 inch), and the surfaces shall be cleaned in accordance with SSPC-SP 11. The underlayment shall be applied to the panels at a thickness of 6.4 millimeters (0.25 inch) and allowed to cure to service at referee conditions in accordance with manufacturer's instructions. The initial Shore A Durometer hardness shall be measured and recorded in accordance with ASTM D2240. The panels shall then be immersed in a 10 percent sodium chloride solution for 15 days, during which time a continuous stream of air shall be passed through the solution, in order to promote corrosion. Immediately after removal from this solution, the Shore A durometer hardness shall again be measured and recorded. Compare the initial hardness reading with the hardness measured after exposure to determine whether the material has softened or detached from the steel backing plates. Probe all sample panel edges with a dull putty knife to determine if the underlay has detached or disbonded from the steel substrate. A portion of the deck covering underlay material shall then be removed carefully from the steel plates, and the substrate visually examined for signs of rusting or corrosion of the steel plate beneath the underlayment.

4.5.11 Fire performance. The product shall be fire tested in accordance with the requirements specified in MIL-STD-1623 for underlay and the test results submitted by the manufacturer to the Government.

4.5.12 Adhesive strength. Eighteen panels shall be prepared in accordance with 4.4.1, with the exception that the panels shall be 200 by 50 by 3.18 millimeters (6 by 2 by 0.125 inch). Underlayment shall be applied to the panels to a thickness of 6.4 millimeters (0.25 inch) in such a way that it only covers a 50- by 50-millimeter (2- by 2-inch) square on each specimen. By using a wooden template, the underlayment shall be applied such that 25 millimeters (1 inch) of the steel plate is exposed at one end, and 75 millimeters (3 inches) exposed at the opposite end. The measurement of adhesive strength by shear stress test shall be run under referee conditions. All specimens shall be tested by compression loading at a rate of 6.4 millimeters (0.25 inch) per minute. Using the test jig shown below in Figure 1, measure the load required to shear the 50- by 50-millimeter (2- by 2-inch) square area of deck covering underlayment from the steel backing.

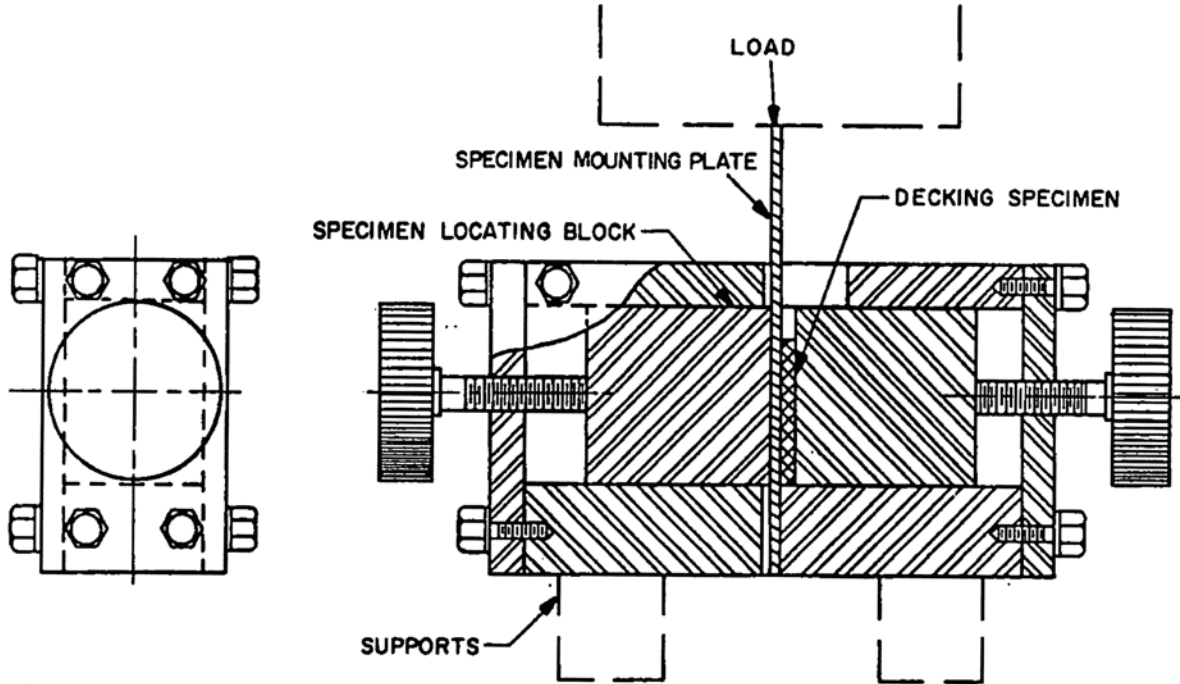

FIGURE 1. Shear test jig for hard-setting deck covering materials.

4.5.12.1 Initial adhesive strength. Calculate the shear stress at failure in Newtons per square meter or Pascals for all six specimens by dividing the load at failure in Newtons by 0.0025 square meter (4 square inches). Average the readings of the six samples and report this as the average initial adhesive strength in kilopascals (1kPa=1000 Pa).

4.5.12.2 Adhesive strength after aging. The next six specimens shall be aged in an oxygen bomb for 96 hours under a pressure of 2000 kilopascals (300 pounds per square inch) and temperature of  $70 \pm 2$  °C ( $158 \pm 2$  °F). Calculate the shear stress at failure in Newtons per square meter or Pascals for all six specimens by dividing the load at failure in pounds by 0.0025 square meter (4 square inches). Average the readings of the six samples and report this as the average adhesive strength after aging in kilopascals (1kPa=1000 Pa).

4.5.12.3 Adhesive strength after exposure. The remaining six specimens shall be exposed to one complete moisture and temperature cycle as defined in 4.5.7. Calculate the shear stress at failure in Newtons per square meter for all six specimens by dividing the load at failure in pounds by 0.0025 square meter (4 square inches). Average the readings of the six samples and report this as the average adhesive strength after exposure in kilopascals (1kPa=1000Pa).

4.5.13 Flexibility (Type IV only). Three panels shall be prepared, the underlayment applied and cured under referee conditions in accordance with manufacturer's instructions, and then removed from the steel backing plate as described in 4.5.8. Each specimen without the steel backing plate shall be bent 180 degrees over a 3.18-millimeter (0.125-inch) mandrel. The samples shall be visually inspected for chipping, cracking, or permanent deformation.

4.5.14 Serviceability. The underlayment shall be applied in NAVSEA designated or approved representative areas aboard a U.S. Naval vessel for a minimum service period of 6 months.

4.5.15 Off-gassing (Grade A only). The underlayment system (including required primer and/or bond coat) shall be tested in accordance with Chapter 7 of NAVSEA S9510-AB-ATM-010 by a Government approved testing facility. The results shall be submitted to the Government for evaluation and approval for use (see 3.5.15 and 6.6).

## 5. PACKAGING

5.1 Packaging. For acquisition purposes, the packaging requirements shall be as specified in the contract or order (see 6.2). When packaging of materiel is to be performed by DoD or in-house contractor personnel, these personnel need to contact the responsible packaging activity to ascertain packaging requirements. Packaging requirements are maintained by the Inventory Control Point's packaging activities within the Military Service or Defense Agency, or within the military service's system commands. Packaging data retrieval is available from the managing Military Department's or Defense Agency's automated packaging files, CD-ROM products, or by contacting the responsible packaging activity.

## 6. NOTES

(This section contains information of a general or explanatory nature that may be helpful, but is not mandatory.)

6.1 Intended use. The deck covering underlay material covered by this specification is intended for use in fairing of steel and aluminum decks prior to applying the following: latex mastic or terrazzo deck covering materials specified in MIL-D-3134, cosmetic polymeric deck covering materials specified in MIL-PRF-24613, porcelain or quarry tiles specified in ANSI A137.1, vinyl composition or solid vinyl tiles specified in ASTM F1066 and ASTM F1700 (respectively), halogen-free wear resistant deck tiles specified in MIL-PRF-32170, and electrical grade sheet specified in MIL-DTL-15562.

6.2 Acquisition requirements. Acquisition documents should specify the following:

- a. Title, number, and date of this specification.
- b. Type, Class, and Grade required (see 1.2).
- c. The specific issue of individual documents referenced (see 2.2.1, 2.2.2, and 2.3).
- d. Packaging requirements (see 5.1 and 6.9).
- e. Whether MSDS and ASTM F718 data sheets are required with each shipment (see 6.5).
- f. Batch VOC certification (see 6.8).
- g. Toxicity conformance (see 3.5.1 and 6.7).
- h. Off-gassing conformance, when required (see 3.5.15 and 6.6).

6.3 Source of documents. The following are the sources for obtaining documents referenced in this section.

6.3.1 ASTM International. ASTM standards are available from ASTM International, 100 Barr Harbor Dr., P.O. Box C700, West Conshohocken, PA 19428-2959 or online at [www.astm.org](http://www.astm.org).

6.3.2 Code of Federal Regulations. Copies of the Code of Federal Regulations are available from the Superintendent of Documents, U.S. Government Printing Office, Washington DC 20401 or online at [www.gpoaccess.gov/index.html](http://www.gpoaccess.gov/index.html).

6.3.3 Defense specifications and Federal standards. Defense specifications and Federal standards are available online at <http://assist.daps.dla.mil/quicksearch/> or <http://assist.daps.dla.mil> or from the Standardization Document Order Desk, 700 Robbins Avenue, Building 4D, Philadelphia, PA 19111-5094.

6.4 Qualification. With respect to products requiring qualification, awards will be made only for products which are, at the time of award of contract, qualified for inclusion in Qualified Products List QPL No. 3135, whether or not such products have actually been so listed by that date. The attention of the contractors is called to these requirements, and manufacturers are urged to arrange to have the products that they propose to offer to the Federal Government tested for qualification in order that they may be eligible to be awarded contracts or orders for the products covered by this specification. Information pertaining to qualification of products may be obtained from Commander, Naval Sea Systems Command, SEA 05Q, 1333 Isaac Hull Avenue, SE, Stop 5160, Washington Navy Yard DC 20376-5160 or emailed to [CommandStandards@navy.mil](mailto:CommandStandards@navy.mil).

6.5 Material safety data sheets. When required, contracting officers will identify those activities requiring copies of completed Material Safety Data Sheets prepared in accordance with FED-STD-313. In order to obtain the MSDS, FAR clause 52.223-3 must be in the contract.

6.6 Off-gassing. Grade A underlayment systems to be installed in submarines are to be controlled to prevent off-gassing, which contaminates the atmosphere and results in health hazards to personnel or deleterious effects on machinery. These controls are accomplished through the Submarine Material Control Program, which is described in Chapter 7 of NAVSEA S9510-AB-ATM-010. Under the Submarine Material Control Program, all materials considered for use on submarines require certification and assignment of a usage category. Under the certification process, candidate materials are selected by Navy activities or contractors, and a request for certification is submitted to Commander, Naval Sea Systems Command, SEA 05Z9, 1333 Isaac Hull Ave., SE, Stop 5122, Washington Navy Yard DC 20376-5122. The certification request is accompanied by detailed information, including descriptions of the material, method of application, usage, and storage. A chemical analysis is conducted, which is normally accomplished through off-gas testing. The off-gas test is required to be conducted in a Government approved laboratory designated by the preparing activity. Information pertaining to this test requirement may be obtained from this same address. Based on the chemical analysis results, a usage category is assigned to the material defining whether, and to what extent, the material may be used on submarines.

6.7 Toxicity evaluation. BUMED INST 6270.8 contains instructions for how an administrative Health Hazard Assessment (HHA) is to be conducted. The Navy and Marine Corps Public Health Center requires sufficient information to permit an HHA of the product. Any questions concerning toxicity, information required to conduct an HHA, and requests for HHAs should be addressed to the Commanding Officer, Navy and Marine Corps Public Health Center, ATTN: Industrial Hygiene Dept./HHA, 620 John Paul Jones Circle, Suite 1100, Portsmouth, VA 20378-2103. Upon receipt of the HHA, a copy should be provided to Commander, Naval Sea Systems Command, SEA 05P, 1333 Isaac Hull Ave., SE, Stop 5133, Washington Navy Yard DC 20376-5133.

6.8 Volatile content. Contracting officers will require the contractor to provide the Government with a written VOC certification, as described in 40 CFR 63.785(a)(2), for each batch of underlay product from which any quantity of the underlayment is supplied to the Government under the contract. The Government reserves the right to reject as defective any underlayment materials for which the VOC certification has not been provided.

6.9 Suggested packaging requirements. Suggested packaging markings are contained in Table VI.

TABLE VI. Suggested marking.

Marking type	Recommended marking
Bar codes	Marking should include bar codes
Hazardous warnings	(a) Labels should be in accordance with 29 CFR Parts 1910, 1915, 1917, 1918, 1926, and 1928.
	(b) All individual containers of latex rubber, resin, or hardener should have the following marking: “CAUTION: This product contains volatile solvents, with probable hazardous vapors. Use with adequate ventilation. Avoid prolonged breathing of vapors or spray mists. The solvents are highly flammable, avoid open flame and smoking.”
	(c) Each component container, shipping container, and palletized load should be marked with the appropriate hazardous symbol in accordance with FED-STD-313.
Volatile organic content (VOC)	“Contains (insert VOC content) grams per liter (insert VOC content in lb/gal) of volatile organic content per 40 CFR 60, Appendix A (EPA) Method 24. Addition of any solvents or thinners is not allowed.”
OSHA Hazard Communication Act and FED-STD-313	Markings should include all information necessary to comply with OSHA Hazard Communication Act and FED-STD-313.
Mixing and use instructions	Labels should include this warning: “Refer to manufacturer’s written mixing and application instructions prior to use.” Two-component resin based products should also contain this warning on each can of resin and hardener: “CAUTION: This is one component of a two component system which WILL NOT HARDEN unless both components are properly mixed together in accordance with manufacturer’s instructions.” Directions should include mixing, application equipment directions, limitations on thinning, temperature range for use, induction and pot life times, and surface preparation recommendations. Directions should refer user to manufacturer’s data sheets or MSDS sheets for information.
Hazardous air pollutants	“Contains (insert HAP content here in g/L and lb/gal) solids (non-volatiles) per 40 CFR 63.”
Shelf life	Labels should include the product’s shelf life expiration date.
Batch tracking information	Lot number, batch number, and date of manufacture.

6.10 Subject term (key word) listing.

Fairing  
 Latex  
 Leveling  
 Lightweight  
 Polymer  
 Ultra-lightweight  
 Underlayment

6.11 Changes from previous issue. Marginal notations are not used in this revision to identify changes with respect to the previous issue due to the extent of the changes.

6.12 MIL-PRF-3135G Grade B. All products qualified to MIL-PRF-3135G are considered to be in conformance with the requirements of MIL-PRF-3135H for Grade B.

Custodians:  
Navy – SH  
Air Force – 99

Preparing Activity:  
Navy – SH  
(Project 5610-2006-002)

Review Activities:  
Navy – CG  
DLA – IS

NOTE: The activities listed above were interested in this document as of the date of this document. Since organizations and responsibilities can change, you should verify the currency of the information above using the ASSIST Online database at <http://assist.daps.dla.mil>.